



# Revista

de Arheologie, Antropologie  
și Studii interdisciplinare

---

Journal of Archaeology, Anthropology  
and Interdisciplinary Studies

**3**

2021

*COLEGIUL EDITORIAL*

**Dr. hab. Valentin DERGACIOV**, editor onorific (Republica Moldova)

**Prof. Paul PETTITT**, editor onorific (Marea Britanie)

**Dr. Angela SIMALCSIK**, editor responsabil (România, Republica Moldova)

**Dr. Alin FRÎNCULEASA** (România)

**Dr. Cristian Eduard ȘTEFAN** (România)

**Dr. Daniel GARVĂN** (România)

**Dr. Denis TOPAL** (Republica Moldova)

**Dr. Bianca PREDA-BĂLĂNICĂ** (Finlanda, România)

**Dr. Adela KOVÁCS** (România)

*COLEGIUL DE REDACȚIE/PEER-REVIEW*

**Dr. Angela SIMALCSIK**, redactor responsabil  
(România, Republica Moldova)

**Prof. Paul PETTITT** (Marea Britanie)

**Dr. Denis TOPAL** (Republica Moldova)

**Dr. Adela KOVÁCS** (România)

**Dr. Gabriel VASILE** (România)

**Dr. Vasile DIACONU** (România)

**Dr. Bianca PREDA-BĂLĂNICĂ** (Finlanda)

**Dr. Vitalij S. SINIK** (Moldova)

**Dr. Dorina ONICĂ** (Republica Moldova)

**Dr. Valentin DUMITRAȘCU** (România)

**Dr. Lucian MUNTEANU** (România)

**Cristina-Elena CORDOȘ** (România)

**Dr. Mariana COCIERU** (Republica Moldova)

**Dr. Ioan Sebastian BRUMĂ** (România)

**Dr. Lavinia GRUMEZA** (România)

**Dr. Ștefan HONCU** (România)

**Dr. Raluca KOGĂLNICEANU** (România)

**Dr. George Bodi** (România)

**Ion CIOBANU**, secretar de redacție  
(Republica Moldova)

**Dr. Alin FRÎNCULEASA** (România)

**Dr. Cristian Eduard ȘTEFAN** (România)

**Dr. Ștefan VASILE** (România)

**Dr. Daniel GARVĂN** (România)

**Dr. Roxana MUNTEANU** (România)

**Dr. doc. Oksana HRYTSYUTA** (Ucraina)

**Dr. Dmitriy KIRICENKO** (Azerbaidjan)

**Dr. Alexandru BERZOVAN** (România)

**Dr. Andrei COROBCEAN** (Republica Moldova)

**Marian LIE** (România)

**Dr. Lilia DERGACIOVA** (România)

**Dr. Robert Daniel SIMALCSIK** (România)

**Dr. Cătălin-George FEDOR** (România)

**Dr. Victor COJOCARU** (România)

**Dr. Bogdan HAIDUC** (România)

**Dr. Vlad VORNIC** (Republica Moldova)

**Alexandru KOVÁCS**, traducător, corector (limba engleză, limba franceză, limba germană) (România)

**Denis TOPAL**, concept copertă (Republica Moldova)

**Bianca PREDA-BĂLĂNICĂ**, concept grafic (România)

**Mihail BĂȚ**, machetare și aranjare în pagină (Republica Moldova)

**Ștefan VASILE**, responsabil cu indexarea revistei (România)

Colegiul de redacție nu răspunde de opiniile exprimate de autori.

Editorial board is not responsible for the opinions expressed by authors.

Toate lucrările publicate în Revista de Arheologie, Antropologie și Studii Interdisciplinare (RAASI) sunt recenzate de specialiști în domeniu (peer-reviewed journal).

Revista de Arheologie, Antropologie și Studii Interdisciplinare (RAASI) este publicația anuală a Institutului de Cercetări Bioarheologice și Etnoculturale (ICBE) din Chișinău.

Revista de Arheologie, Antropologie și Studii Interdisciplinare (RAASI) este indexată începând cu anul 2020 în baza de date internațională [CEEOL](http://CEEOL).



Editare și tipar: Bons Offices

ISSN 2587-3768

E-ISSN 2587-3776

Chișinău 2021

# Cuprins

## STUDII, MATERIALE ȘI NOTE

Adela Kovács, Ionela Luiza Melinte

**Determinări dactiloscopice pe un vas ceramic aparținând culturii Cucuteni, faza A**

*Dactyloscopic analysis on a ceramic vessel belonging to Cucuteni culture, phase A* 7

Кириченко Дмитрий А.

**Обычай искусственной деформации головы (черепа) на территории Азербайджана, Кавказа и Ближнего Востока (неолит-халколит)**

*Obiceiul deformării artificiale a capului (craniului) pe teritoriul Azerbaidjanului, Caucazului și Orientului Apropiat (neolitic-eneolitic) // A custom of artificial head (cranial) deformation on the territory of Azerbaijan, Caucasus and Near East (Neolithic-Chalcolithic)* 37

Ihor V. Pistruil, Oksana A. Hrytsiuta

**Traceological study of lithic artefacts from the Mayaki settlement (Usatovskaya culture)**

*Studiul traseologic al pieselor din silex din așezarea Mayaki (cultura Usatovskaya)* 57

Alin Frînculeasa, Octav Negrea, Cătălin Dîscă, Angela Simalcsik

**Tumulul II de la Strejnicu (județul Prahova) – o prezentare arheologică și bio-antropologică**

*Archaeological and bio-anthropological research in mound II from Strejnicu (Prahova County)* 67

Dmitriy A. Kirichenko

**A new burial of the Late Phase of Kura-Araxes cultural tradition/ early kurgan tradition from Azerbaijan**

*O nouă descoperire funerară atribuită fazei târzii a tradiției culturale Kura-Araxes/tradiția tumulilor timpurii din Azerbaidjan* 105

Cristian Eduard Ștefan

**Așezarea de epoca bronzului de la Bălăceanca, județul Ilfov, România. Unele considerații privind cronologia absolută a culturii Tei**

*The Bronze Age settlement of Bălăceanca, Ilfov County, Romania. Some considerations about the absolute chronology of Tei culture* 119

- József Puskas, Lóránt Darvas  
**A Middle Bronze Age pit at Miercurea Ciuc/Csikszereda - Fodor-Kert (Harghita County, Romania)**  
*O groapă din perioada mijlocie a epocii bronzului de la Miercurea Ciuc/ Csikszereda – Fodor-Kert (județul Harghita, România)* 141
- Vasile Diaconu, Mariana Sîrbu  
**Note about a Bronze Age hoard from the north of the Republic of Moldova and some considerations about the winged axes to the east of the Carpathians**  
*Notă despre un depozit de bronzuri din nordul Republicii Moldova și câteva considerații despre topoarele cu aripioare de la est de Carpați* 165
- Shamil Najafov  
**The Tovuzchay I necropolis (Azerbaijan)**  
*Necropola I de la Tovuzchay (Azerbaidjan)* 173
- Сапожников Игорь В.  
**Башня Неоптолема, Нижнеднестровский вал и Никоний по картам и разведкам середины XIX века**  
*Turnul lui Neoptolem, valul Nistrului inferior și Nikonion conform hărților și sondajelor de la mijlocul secolului al XIX-lea (I. V. Sapozhnykov) // Tower of Neoptolemus, Lower Dniester rampart and Nikonion according to maps and surveys of the middle of the 19th century* 191
- Синика Виталий С., Лысенко Сергей Д., Разумов Сергей Н. Тельнов Николай П.  
**Скифские погребения в курганах группы «Плавни» на Нижнем Днестре**  
*Morminte scitice din grupul tumular „Plavni” din regiunea Nistrului Inferior // Scythian graves in the “Plavni” (“Overflow”) barrow group in the Lower Dniester region* 221
- Агульников Сергей М.  
**Могильник скифской культуры у села Казаклия, Республика Молдова**  
*Necropola scitică de la Cazaclia, Republica Moldova // The Scythian necropolis of Cazaclia, Republic of Moldova* 243
- Lucian Munteanu, Lăcrămioara-Elena Istina  
**O monedă de tip „Adâncata-Mânăstirea” descoperită în situl de la Letea Veche (județul Bacău, România)**  
*A coin of “Adâncata-Mânăstirea” type discovered in the site of Letea Veche (Bacău County, Romania)* 273
- Ștefan Honcu, Angela Simalcsik, Sergiu-Constantin Enea, Dumitru Boghian  
**Noi informații despre necropola „dacilor liberi” de la Costești-Baia, județul Iași, România**  
*New information about the „free Dacian” necropolis from Costești-Baia, Iași County, Romania* 283

- George Dan Hânceanu, Angela Simalcsik  
**Inventar funerar „redescoperit” într-o urnă din necropola dacilor liberi de la Moldoveni, fost Porcești (punctul Dealul Gabăra), județul Neamț, România**  
*Funeral inventory “rediscovered” in an urn from the necropolis of the free Dacians from Moldoveni, former Porcești (Dealul Gabăra point), Neamț County, Romania* 299
- Robert Daniel Simalcsik  
**Analiza sintetică a trei necropole birituale de secol IV d. Hr. din Podișul Central Moldovenesc: Polocin, Pogonești și Săbăoani**  
*Synthetic analysis of three biritual necropolises from the 4<sup>th</sup> century AD from the Central Moldavian Plateau: Polocin, Pogonești, and Săbăoani* 329
- Gabriel Vasile  
**Cimitirul otoman de la Cheia Pazvant I (județul Constanța, România). Analiza osteologică a materialului scheletic uman**  
*Ottoman cemetery from Cheia Pazvant (Constanța County, Romania). Osteological analysis of human skeletal material* 339
- Ștefan Honcu, Angela Simalcsik, Alexandru Berzovan, Robert Daniel Simalcsik  
**Mormântul medieval Cx 872 descoperit pe varianta ocolitoare a municipiului Bacău, România**  
*Mediaeval grave Cx 872 discovered on the highway of Bacău, Romania* 369
- Catalin-George Fedor  
**Studiu de antropologie socială într-o comunitate aflată la confluența a două regiuni istorice ale României (partea a treia)**  
*A social anthropology study in a community situated at the confluence of two Romanian historical regions (third part)* 383
- RECENZII ȘI PREZENTĂRI DE CARTE
- Stanislav Țerna, Mariana Vasilache  
**Figurinele antropomorfe din etapa Cucuteni A din interfluviul pruto-nistean / Anthropomorphic figurines from Cucuteni A stage from the Prut-Dniester interfluve**  
*Cristian Eduard ȘTEFAN* 388
- Lista autorilor / List of authors 392



# A new burial of the Late Phase of Kura-Araxes cultural tradition/early kurgan tradition from Azerbaijan

Dmitriy A. Kirichenko<sup>1</sup>

**Abstract.** The paper brings information about a new burial of the Kura-Araxes cultural tradition from Azerbaijan. The grave was excavated during the construction of SCPX (The South Caucasian Pipeline Expansion project) in February 2018. The grave was located 500 m to the west of Khatynly village, in Tovuz district of Azerbaijan. The tomb was discovered during the works carried out by heavy machinery. The grave chamber of a rectangular shape contained a human skeleton lying on the back with a slight deviation to the right side and with slightly bent knees. The funeral inventory consisted of five ceramic vessels belonging to the late phase of the Kura-Araxes cultural tradition (Martkopi/Bedeni complex). The grave belongs to the Early Bronze Age and dates back to 2500-2300 BC. Most likely, this grave was the main burial of the barrow, the upper part of which has been disturbed and destroyed by agricultural activity in the recent ages.

**Keywords:** Azerbaijan, Early Bronze Age, Kura-Araxes cultural tradition, Martkopi/Bedeni complex, kurgan.

**O nouă descoperire funerară atribuită fazei târzii a tradiției culturale Kura-Araxes/tradiția tumulilor timpurii din Azerbaidjan.** Lucrarea aduce informații despre o înmormântare recent descoperită atribuită tradiției culturale Kura-Araxes din Azerbaidjan. Mormântul a fost săpat în timpul construcției SCPX (The South Caucasian Pipeline Expansion project) în februarie 2018, fiind poziționat la 500 m vest de satul Khatynly, din districtul Tovuz, Azerbaidjan. Mormântul a fost descoperit în timpul lucrărilor realizate cu mașini de mare tonaj. Camera funerară, de formă dreptunghiulară, conținea un schelet uman întins pe spate, cu o ușoară abatere spre partea dreaptă și cu genunchii ușor îndoiți. Inventarul funerar consta în cinci vase ceramice aparținând fazei târzii a tradiției culturale Kura-Araxes (complexul Martkopi/Bedeni). Înmormântarea aparține epocii timpurii a bronzului și este datat în perioada 2500-2300 î. Hr. Cel mai probabil, acest mormânt este principal pentru respectivul tumul, care avea partea sa superioară deranjată și distrusă de activitățile agricole din ultimele epoci.

**Cuvinte cheie:** Azerbaidjan, epoca bronzului timpuriu, tradiția culturală Kura-Araxes, complexul Martkopi/Bedeni, tumul.

<sup>1</sup> Institute of Archaeology, Ethnography and Anthropology, Azerbaijan National Academy of Science, Baku, Azerbaijan; [dmakirichenko@mail.ru](mailto:dmakirichenko@mail.ru)

.....

In February of 2018, during the construction of The South Caucasian Pipeline Expansion (SCPX project) at KP 358, in the pipeline trench, several pit burials were found. After this accidental discovery, the expedition of the Institute of Archaeology and Ethnography of Azerbaijan National Academy of Sciences, led by the author of the following article, started the archaeological excavations of these burials. The topic of this article is grave No. 1, which was opened in the northern part of the trench. The grave was found at about 500 m west from Khatynly village, in Tovuz district of Azerbaijan Republic (**Pl. 1**).

### **Burial description**

At the depth of 2.2 m a burial chamber of rectangular shape (size: length – 2.9 m, width – 1.4 m) has been excavated. The human skeleton was lying on the back with a slight deviation to the right side and with slightly bent knees facing north (**Pl. 2; Pl. 7**). The lower part of the skeleton was crushed during the operation of heavy machinery. Five ceramic vessels were found near a human head in the southeast part of the chamber (**Pl. 8**).

### **Characteristics of the ceramic vessels:**

Small size, black burnished vessel of biconical form, with one arched handle, oval in section (**Pl. 3/1**). On the body there is a slightly traced geometrical pattern. Reddish interior. Flat bottom. Thin walls. Handmade. Clay structure with some sand inclusions. Well burnt. Dimensions: height – 11 cm, width – 13 cm, bottom diameter – 5 cm, rim diameter – 9.7 cm.

Large size, black burnished ceramic vessel of biconical form, with two arched handles, oval in section (**Pl. 3/2**). On the body there is a traced geometrical pattern. Reddish interior. Flat bottom. Thick walls. Handmade. Clay structure with a lot of sand inclusions. Poorly burnt. Dimensions: height – 32 cm, width – 39 cm, bottom diameter – 14.5 cm, rim diameter – 19.5 cm.

Middle size, dark grey burnished ceramic vessel of biconical form, with one normal size arched handle, oval in section, on one side, and a small arched handle, oval in section, on the other side (**Pl. 3/3**). On the body there is a slightly traced geometrical pattern. Reddish interior. Flat bottom. Thin walls. Handmade. Clay structure with a few sand inclusions and well burnt. Dimensions: height – 21 cm, width – 25 cm, bottom diameter – 6.5 cm, rim diameter – 19.5 cm.

Small size, black burnished vessel of biconical form, with one arched handle, oval in section (**Pl. 3/4**). Reddish interior. Flat bottom. Thin walls. Handmade. Clay structure with a few sand inclusions and well burnt. Dimensions: height – 16 cm, width – 18 cm, bottom diameter – 5 cm, rim diameter – 13 cm.



Large size, dark grey, slightly burnished, deep bowl of hemispherical form (Pl. 3/5). There is a horizontal ear-shaped molding on the side. Flat bottom. Thick walls. Handmade. Clay structure with a lot of sand inclusions and poorly burnt. Dimensions: height – 32 cm, width – 39 cm, bottom diameter – 14.5 cm, rim diameter – 19.5 cm.

### Human remains

The anthropological analysis is based on Martin & Saller's (Martin, Saller 1957) and Alekseev & Debec's (Alekseev, Debec 1964) methods of craniometric programme and age estimation. The human remains from the grave were in poor condition. We could take *in situ* only some craniometrical measurements of the skull. The skull belonged to an adult male (approximately 17-25 years old), ovoid form, probably mesocranic; narrow-faced and middle height (70 mm); low (30 mm), narrow (30 mm), hypsiconchy orbits; narrow nose (24 mm), not high (50 mm), mesorrhine. Anthropological type – gracile Mediterranean, probably Caspian anthropological type. The Caspian anthropological type is wide in Azerbaijan since Mesolithic to the Modern times (Kirichenko 2020, p. 169).

### Discussion and conclusions

The vessels from the Khatynly grave have analogies in the ceramics of the late phase of Kura Araxes cultural tradition, especially in the Martkopi/Bedeni complex (Pl. 4). The large, black burnished vessel from Khatynly (No. 2) is similar to the vessels from Martkopi barrow No. 2 (Pl. 9), Tqemlara barrow No. 2, Dalismta barrow No. 5, Kvemo Kartli barrow No. 5. The vessel No. 1 from Khatynly is similar to vessels of Early Trialeti ceramics (Pl. 10), Martkopi barrow No. 2 and No. 4, Kvemo Kartli barrow No. 5.

The monuments of the Kura-Araxes cultural tradition are widespread in almost all regions of Azerbaijan<sup>2</sup>. There were settlements and burials. The burials of the Kura-Araxes culture of Azerbaijan represent simple pit burials with single inhumations and collective burials under barrows with *dromos* type entrance to the tomb. The position of the body in simple pit burials is mostly contracted crouched on left/right side. The position of skeletons in collective burials under barrows is hard to detect, they are more chaotic because these tombs have been used for a long time and with every new burial pushing back the previous one, after the filling of the burial chamber it was set on fire and the tomb structure (which consisted of wooden pillars and roof) collapsed (Dzhalilov, Kirichenko 2017, p. 63).

The radiocarbon dating of the bone samples from the Khatynly burial was made with financial support from the BP Company in the Beta laboratory in Miami

<sup>2</sup> The issue of generations and expansion of the Kura-Araxes cultural tradition in the territory of the Caucasus and Near East is not a topic of our paper and will not be included here.

(USA). The Khatynly burial dates from 2473-2299 cal BC, in 2 sigma domain (Pl. 5-6) and consequently belongs to the Early Bronze Age III.

Azerbaijan archaeologist Q. S. Ismailzade divided the Kura-Araxes archaeological culture of Azerbaijan in three phases (Ismailzade 2008, p. 172): phase I – 3500-3000 BC; phase II – 3000-2700 BC; phase III – 2700-2200 BC. The western archaeologists considered that the Kura-Araxes culture has two main periods: I – 3600/3500-2900 BC and II – 2900-2500 BC (Palumbi, Chataigner 2014, p. 249; Palumbi 2015, p. 14); the interval 2500-2300/2200 BC corresponds to Early Kurgan Tradition (Palumbi 2015, p. 30).

The burial mounds of the Early Kurgan Tradition are made of stones and/or earth and generally have a low chamber, either below or above the ground level; they generally contain one or two skeletons, but «cenotaphs» and examples containing only a few bone fragments are also attested. Burial inventories consist of a small number of vessels associated with a few metal items (weapons, pins) and lithic objects; in two cases, traces of wheel-furrows were detected on the chamber's floor (Rova 2014, p. 64).

The Bedeni barrow complex shows that the large timber structures constructed in a deep rectangular or square grave pit were characteristic. Other tomb types include deep earthen shafts or shallow pits, and the occasional catacomb variety, hewn out of bedrock (Sagona 2017, p. 313). Georgian archaeologist Dr. A. Orjonikidze notes that the kurgans comprising Bedeni group are mostly arranged in earthen pits, and in some cases the pits are fitted with special burial chambers (Orjonikidze 2015, p. 65). The Khatynly tomb looks like a construction of burial chambers from Bedeni group barrows.

We think that the Khatynly grave was the main burial of the kurgan, the burial rite and grave goods having good parallels with burials and artefacts of the Matrkopi/Bedeni complex in Eastern Georgia. The upper part of the mound covering was destroyed in the process of agricultural activity from recent times. The nearest area around the Khatynly burial was used for vineyards and crops. The Khatynly grave at this moment is the only burial feature of the last phase of the Kura-Araxes cultural tradition which belonged to the Early Kurgans Tradition of The Early Bronze Age III from Azerbaijan.

### **Acknowledgements**

I would like to express my gratitude and appreciation to the leaderships of BP, AZFEN and SAIPEM for their help and support during the archaeological excavations, special gratitude to Dr. Prof. N. A. Museibli for scientific advice and recommendations, my thanks to graphic interpreter S. Farmanli for drawing the artefacts and burial chamber of the Khatynly grave.

## Bibliography

- Alekseev, Debec 1964:** V. P. Alekseev, G. F. Debec, *Kraniometriya. Metodika antropometricheskikh issledovaniy*, Moscow, 1964 // Алексеев В. П., Дебеч Г. Ф., *Краниометрия. Методика антропометрических исследований*, Москва, 1964.
- Dzhalilov, Kirichenko 2017:** B. M. Dzhalilov, D. A. Kirichenko, *Kurgany Uzun Rama (arheologiya i paleoantropologiya)*, Vestnik Muzeya Arheologii i Etnografii Permskogo Predural'ya 7, 2017, p. 63-66 // Джалилов Б. М., Кириченко Д. А., *Курганы Узун Рама (археология и палеоантропология)*, Вестник Музея Археологии и Этнографии Пермского Предуралья 7, 2017, с. 63-66.
- Ismailzade 2008:** G. S. Ismailzade, *Azerbajdzhan v sisteme rannebronzovoy kul'turnoj obshchnosti Kavkaza*, Baku, 2008 // Исмаилзаде Г. С., *Азербайджан в системе раннебронзовой культурной общности Кавказа*, Баку, 2008.
- Kirichenko 2020:** D. A. Kirichenko, *Paleoantropologiya Azerbajdzhana (VII v. do n.e. – V v.n.e.)*, Baku, 2020 // Кириченко Д. А., *Палеоантропология Азербайджана (VII в. до н.э. – V в.н.э.)*, Баку, 2020.
- Martin, Saller 1957:** R. Martin, K. Saller, *Lehrbuch der Anthropologie in Systematischer Darstellung, mit Besonderer Berücksichtigung der Anthropologischen Methoden*, Bd. I., Stuttgart, Fischer, 1957.
- Orjonikidze 2015:** A. Orjonikidze, *The earlier period of kurgans in Georgia*, Tbilisi, 2015.
- Rova 2014:** E. Rova, *The Kura-Araxes Culture in the Shida Kartli region of Georgia: An overview*, Paléorient 40, 2, 2014, p. 47-69.
- Palumbi 2015:** G. Palumbi, *The Early Bronze Age of the Southern Caucasus*, Oxford handbook online, Oxford, 2015, p. 1-44.
- Palumbi, Chataigner 2014:** G. Palumbi, C. Chataigner, *The Kura-Araxes Culture from the Caucasus to Iran, Anatolia and the Levant: Between unity and diversity. A synthesis*, Paléorient 40, 2, 2014, p. 247-260.
- Sagona 2017:** A. Sagona, *The Archaeology of the Caucasus: From earliest settlements to the Iron Age*, Cambridge, 2017.

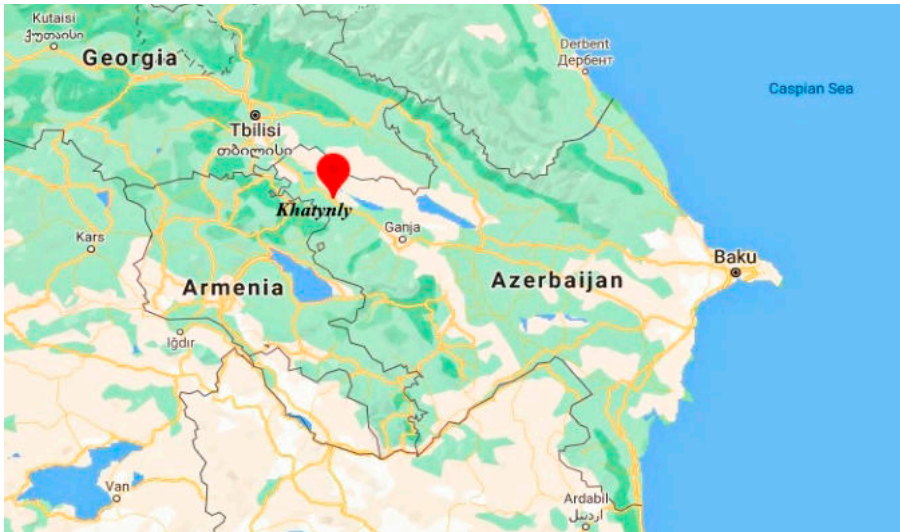

Pl. 1. The topographic position of the site - Khatynly village, Tovuz district, Azerbaijan

Pl. 1. Poziția topografică a sitului - satul Khatynly, districtul Tovuz, Azerbaidjan

(<https://www.google.ru/maps/place/Khatynly,+Azerbaijan/>)

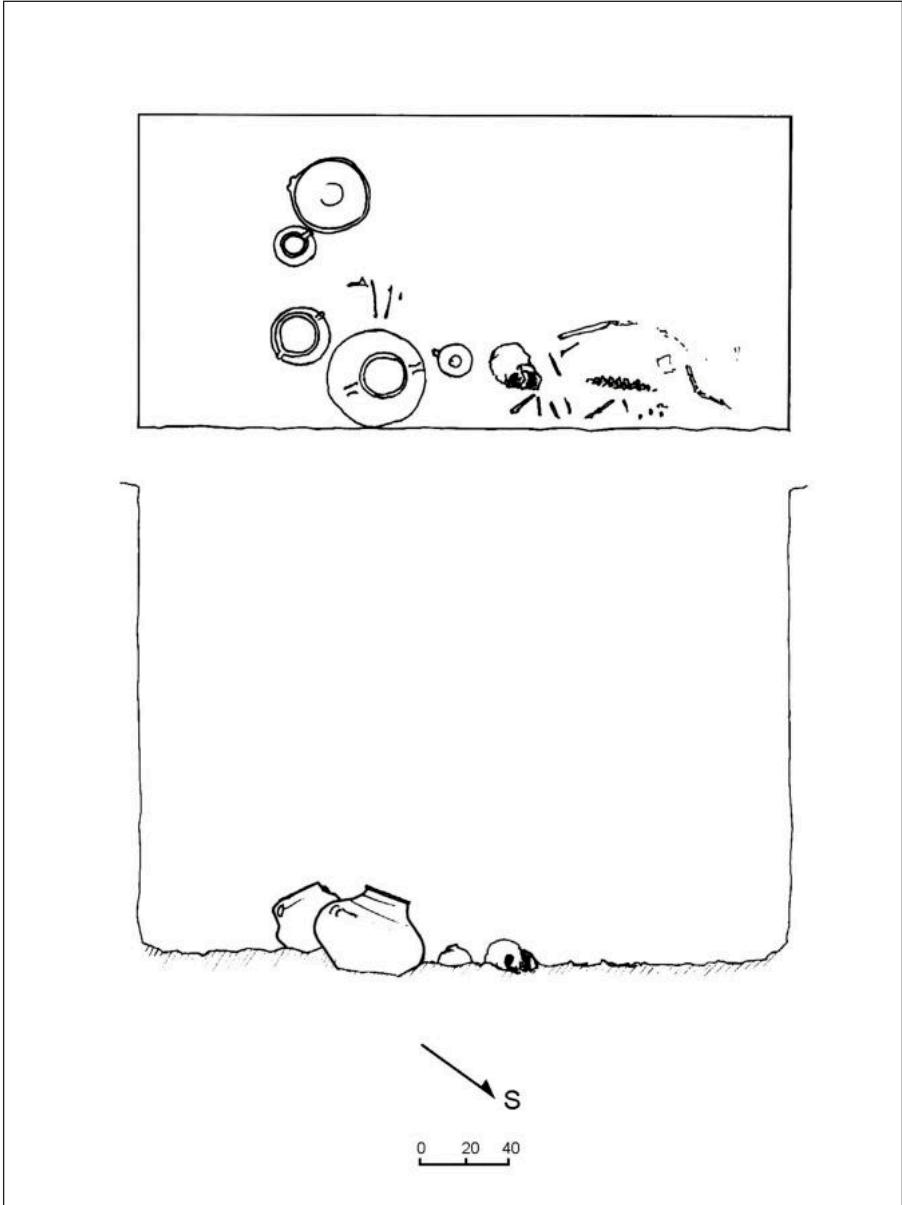

Pl. 2. The Khatynly grave  
Pl. 2. Mormântul de la Khatynly

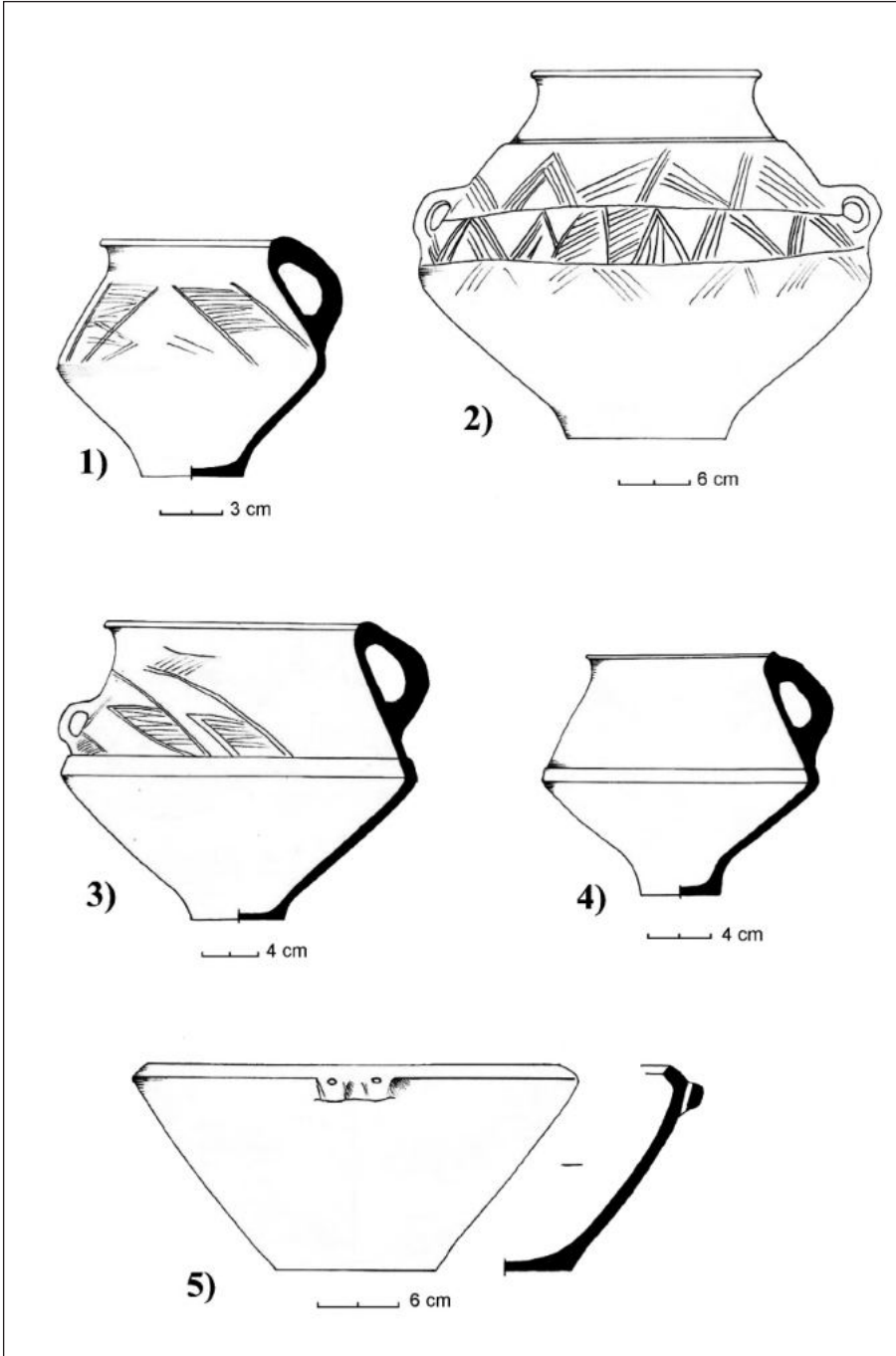

Pl. 3. The ceramic vessels from Khatynly grave  
Pl. 3. Vasele din mormântul de la Khatynly

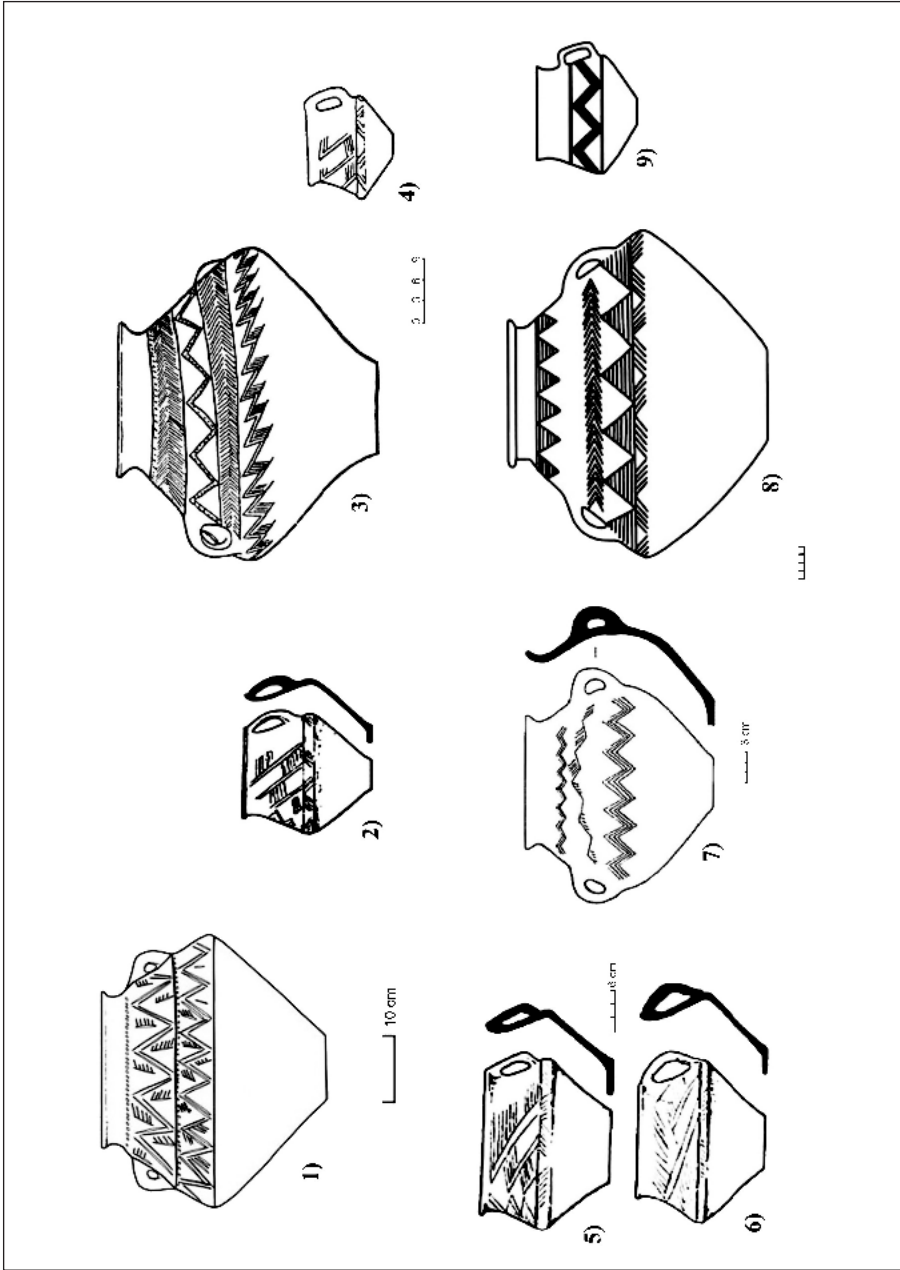

**Pl. 4.** The ceramic vessels of the Martkopi/Bedeni complex of Eastern Georgia (Sagona 2017; Orjonikidze 2015). 1-2. Martkopi, barrow No. 2; 3-4. Kvemo Kartli, barrow No. 5; 5-6. Martkopi, barrow No. 4; 7. Dalismta, barrow No. 5; 8-9. Tqemlara, barrow No. 2.

**Pl. 4.** Vasele din complexul Martkopi/Bedeni din Georgia de Est (Sagona 2017; Orjonikidze 2015). 1-2. Martkopi, tumulul nr. 2; 3-4. Kvemo Kartli, tumulul nr. 5; 5-6. Martkopi, tumulul nr. 4; 7. Dalismta, tumulul nr. 5; 8-9. Tqemlara, tumulul nr. 2.



**Beta Analytic**  
RADIOCARBON DATING

**Beta Analytic Inc**  
4985 SW 74 Court  
Miami, Florida 33155  
Tel: 305-667-5167  
Fax: 305-663-0964  
beta@radiocarbon.com

**Mr. Darden Hood**  
President

**Mr. Ronald Hatfield**  
**Mr. Christopher Patrick**  
Deputy Directors

ISO/IEC 2005:17025-Accredited Testing Laboratory

**REPORT OF RADIOCARBON DATING ANALYSES**

<p>David Maynard Landsker Archaeology</p>	<p>Report Date: July 25, 2018 Material Received: July 05, 2018</p>
---	--

---

Laboratory Number	Sample Code Number	Conventional Radiocarbon Age (BP) or Percent Modern Carbon (pMC) & Stable Isotopes	
Beta - 498813	SCPX358 45	3910 +/- 30 BP	IRMS δ13C: -18.8 o/oo IRMS δ15N: +11.6 o/oo
(95.4%)	2473 - 2299 cal BC	(4422 - 4248 cal BP)	

Submitter Material: Bone (Non-heated)  
 Pretreatment: (bone collagen) collagen extraction; with alkali  
 Analyzed Material: Bone collagen  
 Analysis Service: AMS-Standard delivery  
 Percent Modern Carbon: 61.46 +/- 0.23 pMC  
 Fraction Modern Carbon: 0.6146 +/- 0.0023  
 D14C: -385.38 +/- 2.30 o/oo  
 Δ14C: -390.41 +/- 2.30 o/oo(1950:2,018.00)  
 Measured Radiocarbon Age: (without d13C correction): 3910 +/- 30 BP  
 Calibration: BetaCal3.21: HPD method: INTCAL13  
 Carbon/Nitrogen: CN : 3.3 %C: 31.67 %N: 11.15

---

Results are ISO/IEC-17025:2005 accredited. No sub-contracting or student labor was used in the analyses. All work was done at Beta in 4 in-house NEC accelerator mass spectrometers and 4 Thermo IRMSs. The "Conventional Radiocarbon Age" was calculated using the Libby half-life (5568 years), is corrected for total isotopic fraction and was used for calendar calibration where applicable. The Age is rounded to the nearest 10 years and is reported as radiocarbon years before present (BP), "present" = AD 1950. Results greater than the modern reference are reported as percent modern carbon (pMC). The modern reference standard was 95% the IAC signature of NIST SRM-4990C (oxalic acid). Quoted errors are 1 sigma counting statistics. Calculated sigmas less than 30 BP on the Conventional Radiocarbon Age are conservatively rounded up to 30. d13C values are on the material itself (not the AMS d13C). d13C and d15N values are relative to VPDB-1. References for calendar calibrations are cited at the bottom of calibration graph pages.

Pl. 5. The Khatynly burial, radiocarbon data  
 Pl. 5. Data radiocarbon a mormântului de la Khatynly

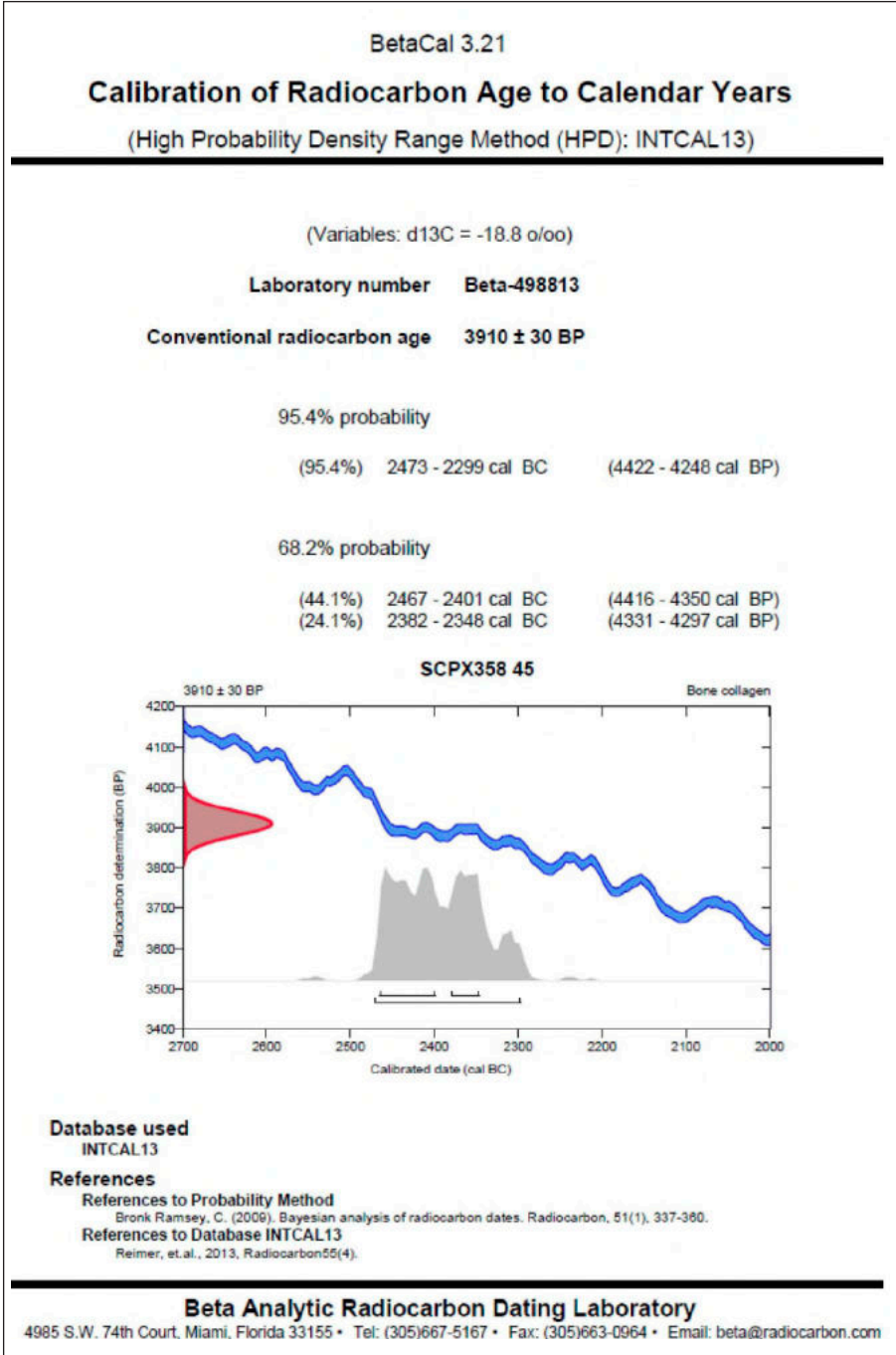

Pl. 6. The Khatynly burial, radiocarbon data  
Pl. 6. Data radiocarbon a mormântului de la Khatynly





Pl. 7. The Khatynly burial, *in situ* photo  
Pl. 7. Mormântul de la Khatynly, fotografie *in situ*



**Pl. 8.** The ceramic vessels from the Khatynly burial  
**Pl. 8.** Vasele descoperite în mormântul de la Khatynly



**Pl. 9.** The vessel from Martkopi, Georgian National Museum, Tbilisi  
(photo credit: the author)

**Pl. 9.** Vasul de la Martkopi, Muzeul Național din Georgia, Tbilisi (fotografia autorului)



**Pl. 10.** The Early Trialeti ceramic vessel (Sagona 2017, Pl. 7.5, p. 312)

**Pl. 10.** Vasul de la Trialeti (Sagona 2017, Pl. 7.5, p. 312)

